

HOLDUP OF THE LIQUID SLUG IN TWO PHASE INTERMITTENT FLOW

DVORA BARNEA and NEIMA BRAUNER

Faculty of Engineering, Department of Fluid Mechanics and Heat Transfer, Tel-Aviv University,
Ramat-Aviv 69978, Israel

(Received 29 May 1983; in revised form 20 February 1984)

Abstract—A physical model for the prediction of gas holdup in liquid slugs in horizontal and vertical two phase pipe slug flow is presented. This model can also be used to yield the transition between elongated bubbles and slug flow within the intermittent flow pattern. In addition a previously published model for predicting the stable slug length in vertical upward slug flow (Taitel *et al.* 1980) is extended here for the case of horizontal slug flow.

INTRODUCTION

A comprehensive physical model for horizontal gas-liquid slug flow has been presented by Dukler & Hubbard (1975), and was modified and extended by Nicholson *et al.* (1978). However these models are not a complete predictive tool as supplementary data is required in order to initiate the calculation procedure. These are the liquid volume fraction within the liquid slug (R_s) and the slug frequency (or the slug length).

Modeling of vertical upward gas liquid slug flow has been recently presented by Fernandes (1981), who developed a semi-mechanistic model to predict the detailed hydrodynamic structure of the flow. The model cannot predict the slug length, while the prediction of R_s is performed indirectly through the use of other empirical correlations.

Thus, it seems that the presently available models for horizontal and vertical slug flows require the in-situ liquid holdup of the slug, R_s , and the slug frequency (or slug length) as input data. The former has been obtained experimentally by Fernandes (1981) in upward vertical slug flow, and by Hubbard (1965) and Gregory *et al.* (1978) for horizontal slug flow. In the Gregory *et al.* study a simple empirical correlation has been obtained between R_s and the mixture velocity within the liquid slug, V_s . Measurements of slug frequency has been reported by Dukler & Hubbard (1975), Grescovich & Shrier (1972), Vermeulen & Ryan (1971) and others.

The slug frequency and slug length are interconnected properties and are very often alternatively used (Nicholson *et al.* 1978). Several experimental observations for water-air systems in vertical upward and horizontal slug flow suggest that the stable liquid slug length, l_s , is insensitive to the gas and liquid flow rates, and is fairly constant for a given tube diameter, D , (Moissis & Griffith 1962, Moissis 1963, Nicholson *et al.* 1978). The stable slug length was observed to be of about $12D-30D$ for horizontal slugs and of about $8D-16D$ for vertical upward slugs.

Recently Moalem-Maron *et al.* (1982) proposed a model to calculate the slug length l_s and slug holdup R_s for a given slug frequency. The model assumed separation of the gas bubbles due to buoyancy forces at the rear part of the liquid slug. It was shown that reduction in slug frequency is accompanied by increasing of R_s and decreasing of the average pressure drop over a slug unit. It has been assumed that a developed slug tends to stabilize at a region of minimum pressure drop and at maximum liquid holdup (i.e. $R_s \rightarrow 1$). The aforementioned analysis overlooks the turbulent forces that tend to maintain homogeneous mixture of the gas bubbles. As a result it may be applicable only in the developing region, where R_s is large and the buoyancy forces dominate. However, in a developed liquid slug, turbulent forces may overcome coalescence forces resulting in a well dispersed bubble flow within the liquid slug with $R_s < 1$.

The present work proposes a mechanistic model for the prediction of R , in a developed slug. In addition a previously published model for predicting the stable slug length in vertical upward slug flow (Taitel *et al.* 1980) is extended here for the case of horizontal slug flow.

PREDICTION OF R ,

The present model assumes that the gas in a developed liquid slug appears as dispersed bubbles. The gas hold-up that the liquid slug can accommodate as dispersed bubbles is to be determined from a balance between breakage forces due to turbulence and coalescence forces due to gravity and/or surface tension. Whenever coalescence dominates, agglomeration of small bubbles occurs, leading into formation of elongated ones, which are separated by aerated liquid slugs. On the other hand, with increasing turbulence, breakage forces will ultimately lead into a fully dispersed bubble flow pattern. This very same balance also determines the transition boundary between dispersed bubble and slug flow (Taitel & Dukler 1976; Taitel *et al.* 1980; Barnea *et al.* 1982).

The condition for horizontal slug-dispersed bubble transition has been obtained by using turbulence as breaking forces and buoyancy as coalescent forces (Taitel & Dukler 1976) and is given by:

$$U_L = \left[\frac{4A_G g \cos \beta}{S_i f_L} \left(1 - \frac{\rho_G}{\rho_L} \right) \right]^{1/2} \quad [1]$$

where A_G and S_i are the gas cross sectional area and the interfacial perimeter respectively for stratified equilibrium flow, U_L is the liquid velocity for stratified flow and f_L is its friction factor. The gas and liquid densities are ρ_G and ρ_L respectively, g is the gravitational acceleration and β the angle of inclination from the horizontal. The transition line is represented by the line $A-B$ on figure 1.

Consider a point on the dispersed bubble-slug transition boundary $A-B$. This point is identified for a certain system by the gas and liquid superficial velocities (V_{GS} and V_{LS}). The gas hold-up (α) at this point can be easily calculated, assuming no slip flow, by:

$$\alpha = \frac{V_{GS}}{V_{GS} + V_{LS}} \quad [2]$$

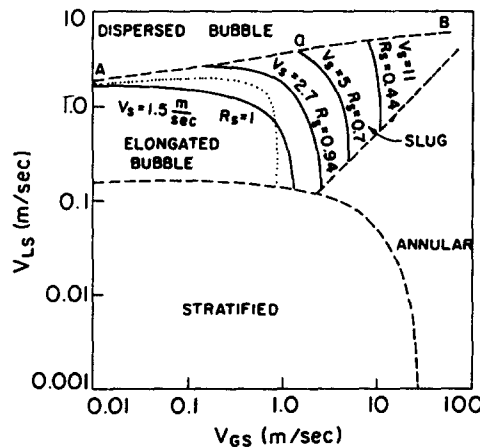

Figure 1. Locus of constant R , and slug-elongated bubble transition boundary. Air-water, horizontal $D = 2.54$ cm: -----, theoretical transition boundaries (Taitel & Dukler 1976); —, calculated R_n , present model ($R_n = 1$ is the elongated bubble slug transition); experimental elongated bubble-slug transition (Shoham 1982).

The gas hold-up on the transition line is the maximum hold-up that the liquid slug can accommodate as fully dispersed bubble pattern at a given turbulent level, which is determined by the mixture velocity $V_M = (V_{GS} + V_{LS})$.

Starting for instance at point (a) on the slug-dispersed bubble transition line (figure 1), increasing V_{GS} while maintaining V_M constant, will cause transition to slug flow, where elongated bubbles are formed by the excess of gas that cannot be accommodated by the liquid. However, a simple mass balance dictates that the mixture velocity within the liquid slug V_s equals V_M . Therefore, along a line of constant $V_s (= V_M)$ the turbulent level within the slug is maintained on the same level as in dispersed bubble flow. As a result the liquid slug will accommodate the same amount of gas hold-up as that of fully dispersed bubble flow at point (a) on the transition boundary. Stated differently, curves of constant V_s represent the locus where the gas hold-up within the liquid slug, $\alpha_s = 1 - R_s$, is constant and is equal to the hold-up of the dispersed bubble pattern at the transition boundary (α as defined by [2]). The transition boundary itself may be obtained by any reliable predictive model or even experimentally. Once it is obtained, R_s is determined based on the above concept. Clearly, as the liquid properties or the pipe diameter are changed, the location of the transition line will change, and R_s accordingly.

The predicted values of R_s are compared with a recent experimental correlation suggested by Gregory *et al.* (1978) for light refined oil ($\rho_L = 858 \text{ kg} \cdot \text{m}^{-3}$) and air slug flow. Their experiments indicate a modest diameter effect and for a given two phase flow system R_s is a function of V_s only. As shown in figure 2 the agreement between the predicted values and experiments is satisfactory. Note that the calculation is based on the predicted slug-dispersed bubble transition line (Taitel & Dukler 1976). If actual experimental data for the transition line is used the agreement for R_s is even better.

In upward vertical slug flow R_s can be evaluated using the same concept suggested for horizontal flow. Based on mechanisms of breakup and coalescence of bubbles in turbulent flow, the transition boundary between dispersed bubbles and slugs in vertical flow has been found to be (Barnea *et al.* 1982):

$$2 \left[\frac{0.4\sigma}{(\rho_L - \rho_G)g} \right]^{1/2} \left(\frac{\rho_L}{\sigma} \right)^{3/5} \left[\frac{2}{D} C_L \left(\frac{D}{v_L} \right)^{-n} \right]^{2/5} V_M^{2(3-n)/5} = 0.725 + 4.15 \left(\frac{V_{GS}}{V_M} \right)^{1/2} \quad [3]$$

where σ is the surface tension and v_L the liquid kinematic viscosity. C_L and n are coefficients in the friction factor Blasius correlation ($C_L \approx 0.046$ $n \approx 0.2$). However regardless of how much turbulence is available, it was assumed that bubble flow cannot exist at void fraction above $\alpha = 0.52$.

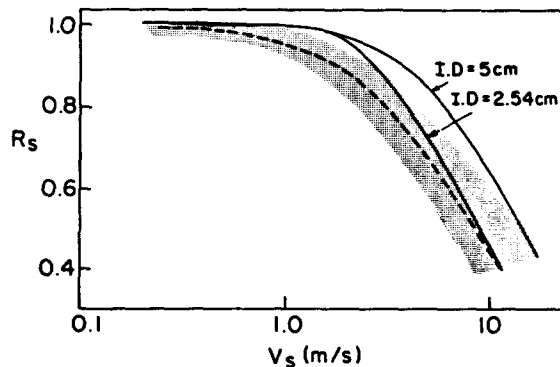

Figure 2. Liquid holdup within the liquid slug: —, model proposed in this work; ----, correlation [1] and range of data (Gregory *et al.* 1978). Horizontal flow.

Figure 3 shows this transition line $B-C-D$ as well as curves of constant V_r and R_s for vertical slug flow in a 1.25 cm dia. pipe (typical for pipes with $D < 5$ cm).

For larger pipe diameter Taitel *et al.* (1980) showed that bubble flow pattern can exist below the transition line represented by [3], provided that the pipe diameter is larger than $D > 19[(\rho_L - \rho_G)\sigma/\rho_L^2g]^{1/2}$ ($D \geq 5$ cm for an air-water system) and the gas hold-up is below $\alpha = 0.25$. These conditions represent the situation where coalescence is negligible and bubbles keep their separate identity even under relatively low liquid rate. Thus, for pipes with $D \geq 5$ cm the boundary between dispersed bubble and slug flow is composed of 3 different sections depending on the mechanism of transition (figure 4): section $A-B$ is the transition line of $\alpha = 0.25$, section $C-D$ is that of $\alpha = 0.52$ (Taitel *et al.* 1980) and section $B-C$ is the transition line caused by turbulent breakage [3].

It can be seen (figure 4) that in large diameter pipes, over a wide range of slug flow, lines of constant V_r intersect the transition line $A-B$ and R_s in this range (ABE in figure 4) is therefore constant and equal to 0.75. This result agrees well with the experimental data obtained by Fernandes (1981) (figure 4).

ELONGATED BUBBLE-SLUG TRANSITION

An additional benefit of the proposed model is the ability to distinguish between elongated bubbles and slugs within the intermittent flow pattern. The distinction between elongated bubbles and slugs is yet not well defined, it is usually assumed (Barnea *et al.* 1980) that elongated bubbles are the limiting case of slug flow, where the liquid slug is almost free of entrained gas bubbles. A prediction for the elongated bubble-slug transition boundary has not yet been reported although experimental data (Mandhan *et al.* 1974; Barnea *et al.* 1980) do distinguish between elongated bubble and slug flow. Consistent with the present model, the curve for the constant V_r where $R_s \rightarrow 1$ is the elongated bubble-slug boundary transition. This transition criteria is mapped on figure 1 and indicates a satisfactory agreement with the experimental results.

Note that also in the vertical case $R_s = 1$ is a boundary between a region of aerated slugs and slugs free of entrained bubbles (elongated bubbles in the horizontal case). This boundary agrees well with the experimental results (figure 3).

SLUG LENGTH PREDICTION (4)

Slug frequency is usually thought as an entrance phenomena, namely it results from bridging of the liquid at the entrance (Taitel & Dukler 1977). However, close observations

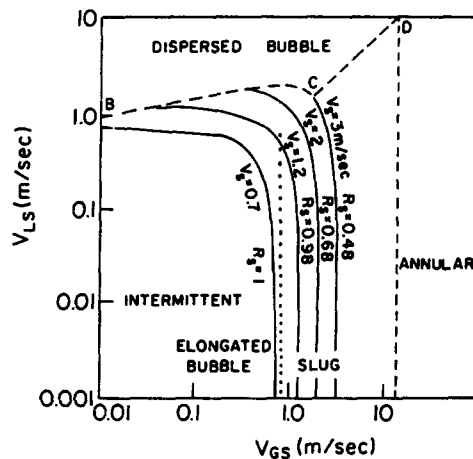

Figure 3. Locus of constant R_s and slug-elongated bubble transition boundary. Air-water, upward vertical $D = 1.25$ cm: -----, theoretical transition boundaries (Taitel *et al.* 1980; Barnea *et al.* 1982); —, calculated R_s , present model ($R_s = 1$ is the elongated bubble-slug transition); ·····, experimental elongated bubble-slug transition (Luninski 1981).

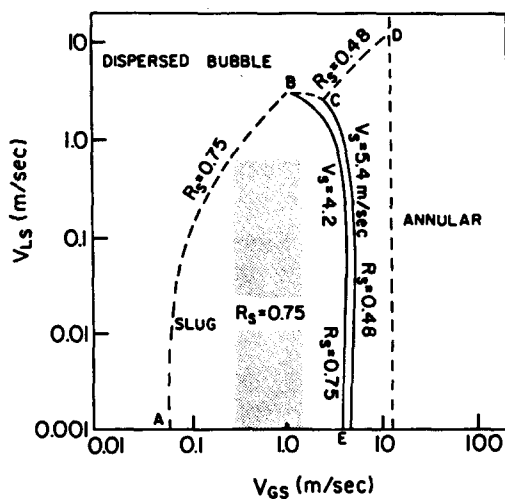

Figure 4. Locus of constant R_s . Air-water, upward vertical $D = 5$ cm: - - - - -, theoretical transition boundaries (Taitel *et al.* 1980); —, calculated R_s , present model (shaded area). Experimental results (Fernandes 1981).

on the slug frequency and the slug length indicate that short (high frequency) slugs are usually formed at the entrance, and these are unstable: Shedding of liquid at the rear of the liquid slug seems to be larger for short slugs. As a result the shorter slugs tend to merge with the upstream following slug. During this process the elongated bubble behind the short slug is seen to overtake the bubble ahead of it. Thus, both liquid slugs and bubbles grow and the slug frequency decreases. The process continues until the liquid slugs are long enough to be stable.

The same process is observed for vertical upward flow and it was described in detail by Taitel *et al.* (1980) who suggested that a stable slug is the one which is long enough such that the velocity profile at the slug rear is already fully developed. The stable slug length was analyzed by Taitel *et al.* (1980) as follows: referring to figure 5 two consequent Taylor bubbles are shown. The first (top) Taylor bubble is behind a long steady liquid slug. The velocity profiles at the front and behind this bubble is shown schematically in figure 5. The velocity profile in front of bubble (A) (at the bottom of the long liquid slug) is a fully developed turbulent flow profile with a center velocity of approximately $V_c = 1.2 V_f$. Behind bubble (A) the velocity profile in the liquid slug is distorted by the falling film flow behind the Taylor bubble (figure 5). Since the average total mixture velocity at any cross

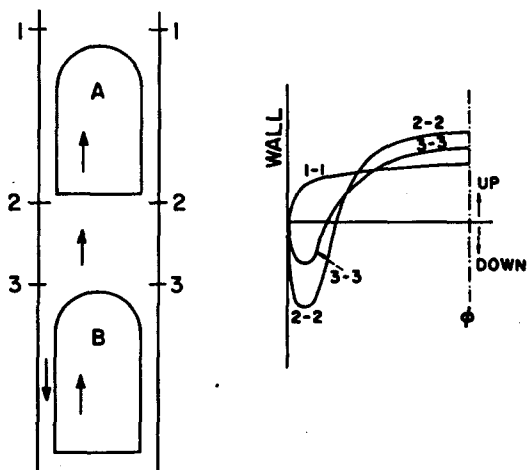

Figure 5. Velocity profiles in the liquid slug.

section of the slug is the same and equals to V_f , it is obvious that the center line velocity V_C decreases asymptotically to $1.2 V_f$ with distance from the trailing edge of the Taylor bubble. Since the Taylor bubble velocity is given by Nicklin *et al.* (1962):

$$V_T = V_C + 0.35 \sqrt{gD} \quad [4]$$

it is clear that the second bubble which is behind a short liquid slug will overtake the first bubble which has a center velocity of $1.2 V_f$. Thus the question of determining the length of a stable slug reduces to the problem of calculating the length needed to establish a fully developed velocity profile.

The liquid film that flows down along the Taylor bubble has a velocity $(V_f + V_T)$ relative to the Taylor bubble velocity. This liquid sheet was considered as a two dimensional jet, which enters a stagnant pool of liquid (the slug) at a uniform velocity $(V_f + V_T)$. The axial velocity u in the liquid, induced by the jet, depends on distance x in the direction of the jet and y , the normal distance from the jet centerline.

$$\frac{u}{u_{\max}} = 1 - \tanh^2 \gamma \left(\frac{y}{x} \right) \quad [5]$$

where γ is a universal constant approximately equal to 7.67 (Schlichting 1968). Taitel *et al.* (1980) suggested that a developed slug length is equal to the distance downstream at which the jet has been absorbed by the liquid. In this case at a distance $x = l_s$ and $y = D/2$ the velocity is essentially flat, say $u/u_{\max} \leq 0.05$ and thus the normal turbulent distribution in the liquid slug is undisturbed. Solving [5] show that this situation takes place at $l_s/D = 16$.

In horizontal slug flow the situation is similar to the vertical case with the exception that in vertical flow the liquid film (jet) penetrating the slug is symmetrical, whereas in the horizontal case the liquid film is only at the tube bottom. The stable slug length may be evaluated as before using [5], with the condition of $u/u_{\max} < 0.05$, at the normal distance $y = D$ (rather than $D/2$). This leads to a stable slug length of $32D$, which is twice the length of the stable vertical liquid slug. This result is in good agreement with the experimental results of Gregory *et al.* (1978) and somewhat higher than the length measured by Dukler & Hubbard (1965).

SUMMARY AND CONCLUSIONS

(a) A model for the prediction of the liquid slug void fraction is presented. The method is based on the assumption that the gas within the developed liquid slug behaves as dispersed bubbles, and thus the liquid slug will accommodate the same gas holdup as the fully dispersed bubble flow on the transition boundary with the same mixture velocity.

(b) The modeling of R_s is independent of the prediction of other slug flow characteristics and the only information needed is the dispersed bubble slug transition boundary, which may be obtained by existing models or by experimental results.

(c) The predicted values of R_s show satisfactory agreement with experimental results.

(d) The proposed model for predicting R_s can also be used to predict the slug-elongated bubble transition line.

(e) The minimum stable slug length is the length required to obtain a fully developed velocity profile at the rear of the liquid slug.

(f) Estimation of slug length indicate that the stable slug length is independent upon the gas and liquid flow rates and is constant for a given tube diameter. The estimated stable slug length in horizontal flow ($32D$) is twice the stable length in upward vertical flow ($16D$). These results are in good agreement with experimental results.

(g) The prediction of the liquid slug holdup (R_s) and the slug length (l_s) represents a closure of the previously published models for slug characteristics.

REFERENCES

- BARNEA, D., SHOHAM, O. & TAITEL, Y. 1980 Flow pattern transition for gas-liquid flow in horizontal and inclined pipes. *Int. J. Multiphase Flow* **6**, 217-225.
- BARNEA, D., SHOHAM, O. & TAITEL, Y. 1982 Flow pattern transition for downward inclined two phase flow, horizontal to vertical. *Chem. Engng Sci.* **37**, 135-140.
- DUKLER, A. E. & HUBBARD, M. G. 1975 A modal for gas-liquid slug flow in horizontal and near horizontal tubes. *Ind. Engng Chem. Fundls* **14**, 337-347.
- FERNANDES, R. C. 1981 Experimental and theoretical studies of isothermal upward gas-liquid flows in vertical tubes. Ph.D. Thesis, University of Houston.
- GREGORY, G. A., NICHOLSON, M. K. & AZIZ, K. 1978 Correlation of the liquid volume fraction in the slug for horizontal gas-liquid slug flow. *Int. J. Multiphase Flow* **4**, 33-39.
- GRESCOVICH, E. J. & SHRIER, A. L. 1972 Slug frequency in horizontal gas-liquid slug flow. *Ind. Engng Chem. Proc. Des. Dev.* **11**, 317-318.
- HUBBARD, M. G. 1965 An analysis of horizontal gas-liquid slug flow. Ph.D. Thesis, University of Houston.
- LUNINSKI, Y. 1981 Two phase flow in small diameters lines—flow patterns and pressure drop. Ph.D. Thesis, Tes-Aviv University.
- MANDHAN, J. M., GREGORY, G. A. & AZIZ, K. 1974 A flow pattern map for gas-liquid flow in horizontal pipes. *Int. J. Multiphase Flow* **1**, 537-553.
- MOALEM-MARON, D., YACOUB, N. & BRAUNER, N. 1982 New thoughts on the mechanism of gas-liquid slug flow. *Letters Heat Mass Transfer* **9**, 333-342.
- MOISSIS, R. & GRIFFITH, P. 1962 Entrance effects in a two-phase slug flow. *J. Heat Transfer* **84**, 29-39.
- MOISSIS, R. 1963 The transition from slug to homogeneous two phase flows, *J. Heat Transfer* **85**, 366-370.
- NICHOLSON, M. K., AZIZ, K. & Gregory, G. A. 1978 Intermittent two phase flow in horizontal pipes, predictive models. *Can. J. Chem. Engng* **56**, 653-663.
- NICKLIN, D. J., WILKES, J. O. & DAVIDSON, J. F. 1974 Two phase flow in vertical tubes. *Trans. Inst. Chem. Engrs (London)* **40**, 61-68.
- SCHLICHTING, H. 1968 *Boundary Layer Theory*, 6th Edn. McGraw-Hill, New York.
- SHOHAM, O. 1982 Flow pattern transition and characterization in gas-liquid two phase flow in inclined pipes, Ph.D. Thesis, Tel-Aviv University.
- TAITEL, Y. & DUKLER, A. E. 1976 A model for predicting flow regime transition in horizontal and near horizontal gas-liquid flow. *AIChE J.* **22**, 47-55.
- TAITEL, Y. & DUKLER, A. E. 1977 A model for slug frequency during gas-liquid flow in horizontal and near horizontal pipes. *Int. J. Multiphase Flow* **3**, 585-596.
- TAITEL, Y., BARNEA, D. & DUKLER, A. E. 1980 Modeling flow pattern transition for steady upward gas-liquid flow in vertical tubes. *AIChE J.* **26**, 345-354.
- VERMEULEN, L. R. & RYAN, J. T. 1971 Two phase slug flow in horizontal and inclined tubes. *Can. J. Chem. Engng* **49**, 195-201.